

Embedded Solutions

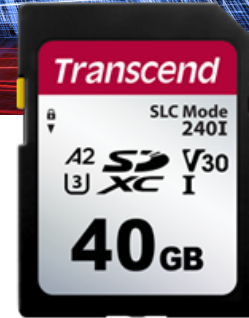

SD Cards

SDC240I

Utilizing top-quality 112-layer 3D NAND flash with SLC Mode technology, and rated to endure 100K P/E cycles, Transcend's SDC240I SD card combines the advantages of high performance and exceptional endurance at an affordable price. Transcend's SDC240I is able to operate in wide operating temperatures of -40°C~85°C, ideal for write-intensive applications such as outdoor transportation, surveillance systems, digital signage, and POS terminals.

Hardware Features

- Compliant with UHS-I
- Compliant with Application Performance Class 2 (A2)
- Compliant with Video Speed Class 30 (V30)
- Endurance: 100K P/E cycles (Program/Erase cycles) guaranteed
- Promised operational reliability in a wide temperature range (from -40°C to 85°C)

Firmware Features

- Early Move
- Supports S.M.A.R.T. function to conduct health monitoring, analysis, and reporting for storage devices
- Built-in ECC (Error Correction Code) functionality
- Wear-Leveling

Ordering Information

20GB	TS20GSDC240I
------	--------------

40GB	TS40GSDC240I
------	--------------

80GB	TS80GSDC240I
------	--------------

160GB	TS160GSDC240I
-------	---------------

Specifications

Appearance	Dimensions	24 mm x 32 mm x 2.1 mm (0.94" x 1.26" x 0.08")
	Form Factor	SD flash card
Storage	Flash Type	112-layer 3D NAND flash (SLC mode)
	Capacity	20 GB / 40 GB / 80 GB / 160 GB
Operating Environment	Operating Voltage	2.7V ~ 3.6V
	Drop Test	1.5m free fall
	Operating Temperature	Wide Temp. -40°C (-40°F) ~ 85°C (185°F)
	Storage Temperature	-40°C (-40°F) ~ 85°C (185°F)
	Humidity	0% ~ 95%
	Shock	Acceleration: 490 m/s ² (standard holding time: 11 ms, semi-sine wave, velocity change: 3.44 m/s)
	Vibration (Operating)	20 G (peak-to-peak), 20 Hz ~ 2000 Hz (frequency)
Power	Power Consumption (Max.)	2.88 watt(s)
Performance	Read Speed (Max.)	Up to 100 MB/s
	Write Speed (Max.)	Up to 80 MB/s
	Terabytes Written (TBW)	Up to 1690 TBW
Warranty	Certificate	CE / UKCA / FCC / BSMI
	Warranty	Three-year Limited Warranty

Mechanical Dimensions

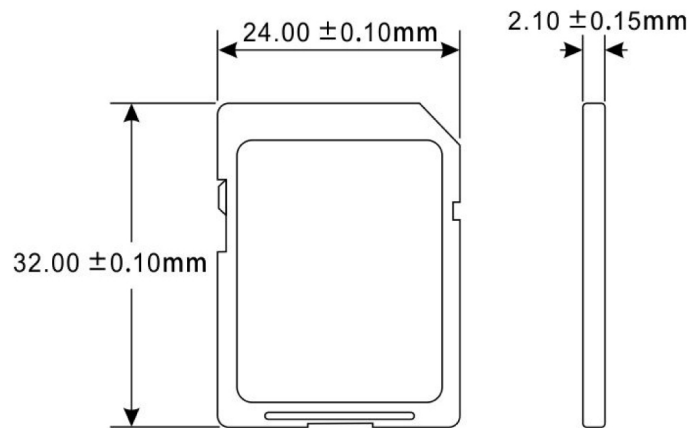

Product specifications are subject to change without notice. Pictures shown may differ from actual products. Total accessible capacity varies depending on operating environment. Due to the complexity and variety of industrial applications, Transcend cannot guarantee 100% compatibility with all platforms and under all scenarios. For special applications and environments, it is strongly suggested that you contact Transcend beforehand for clarification.